

# Florida Board of Education

Strategic Planning Workshop 2

November 19 & 20, 2001

>  
accenture



# Agenda

- **Overview of Strategic Planning**
  - General Approach
  - Legislative Context
  - Recommended Framework
  - Illustrative Strategic Imperative
  
- **Developing BOE's Strategic Imperatives**
  - Education Trends
  - Getting Started

# Agenda

- **Overview of Strategic Planning**

- **General Approach**

- Legislative Context

- Recommended Framework

- Illustrative Strategic Imperative

- **Developing BOE's Strategic Imperatives**

- Education Trends

- Getting Started

The purposes of strategic planning are to articulate a long-term vision for an organization and create a practical plan for achieving it.

### Foci of Strategic Planning

#### Goals

---

#### Knowledge

- Understand the competitive environment and the organization's relative position in it
  - Build awareness of key industry trends
- 

#### Planning

- Develop a clear perspective on future goals and aspirations for the organization
  - Develop statements of vision and strategic intent
- 

#### Performance

- Identify practical initiatives and create an implementation plan
  - Build consensus among key stakeholders
  - Establish standards for measuring results
-

Effective strategic planning begins with a vision of the organization’s desired future state and leads to defined management actions for progressing toward that vision.

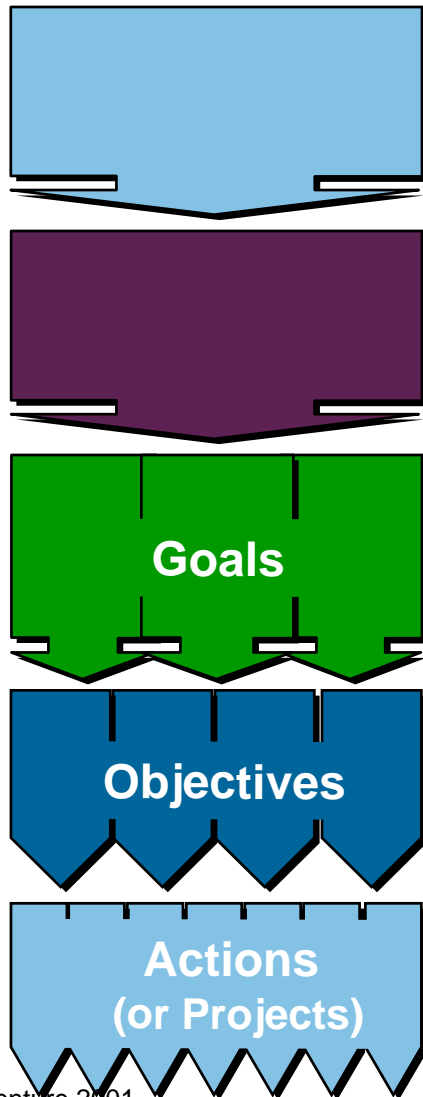

### Components of Strategic Planning

The **Vision** is the state of performance to which the organization aspires for the long term.

---

The **Mission** specifies what the organization will do, whom it will do it for, and how it will measure success as it works toward achieving its vision.

---

**Goals** are the concrete “big picture” results the organization will strive to achieve during a defined period in carrying out its mission.

---

**Objectives** include all significant milestones the organization must pass on the way to achieving specific goals.

---

**Actions** include all management activities essential to attaining specific objectives.

---

Enacting guiding principles, a mission, and clear goals for K-20 education in Senate Bill 1162, the Legislature and Governor together initiated this strategic planning process.

### Phases of Strategic Planning for Florida’s K-20 Education System

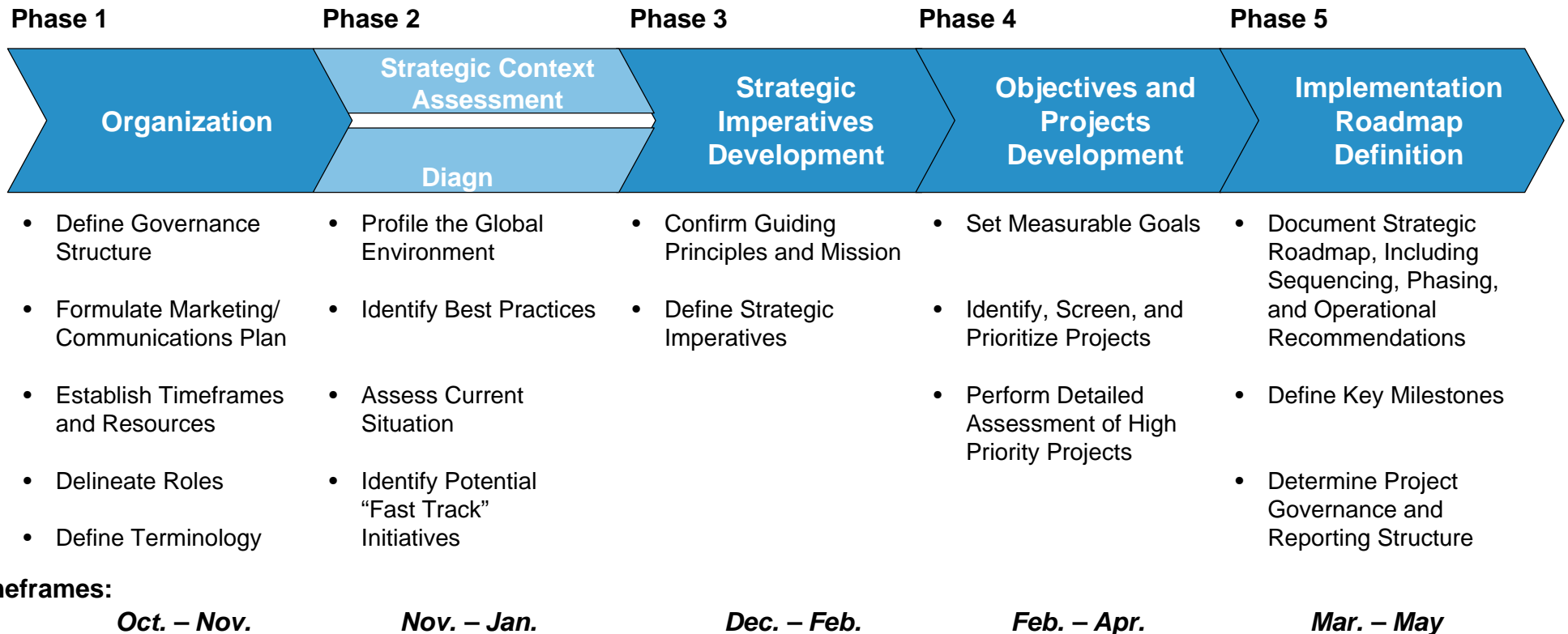

# Agenda

- **Overview of Strategic Planning**

- General Approach

- **Legislative Context**

- Recommended Framework

- Illustrative Strategic Imperative

- **Developing BOE's Strategic Imperatives**

- Education Trends

- Getting Started

**By law, the Florida Board of Education (BOE) is to be the sole strategic planner for the state's K-20 education system.**

### **Excerpts from Senate Bill 1162\***

- “Florida's K-20 education system shall rely on a single entity, the Florida Board of Education, as its single strategic voice.”
- “Members of the Florida Board of Education shall focus on high-level policy decisions.”

Source: SB 1162, Section 8

\*a.k.a. "Florida Education Governance Reorganization Implementation Act of 2000"

**Senate Bill 1162 also stated clearly the required guiding principles, mission, and goals for Florida's K-20 education system.**

### **Guiding Principles for Florida's New Education Governance**

- A coordinated, seamless system for kindergarten through graduate school education
- A system that is student-centered in every facet
- A system that maximizes education access and provides opportunity for a high-quality education and academic success for all Floridians
- A system that safeguards equity and supports academic excellence
- A system that provides for local operational flexibility while promoting accountability for student achievement and improvement and refuses to compromise academic excellence

Source: SB 1162, Section 2

**Senate Bill 1162 also stated clearly the required guiding principles, mission, and goals for Florida's K-20 education system.**

### **Mission of Florida's K-20 Education System**

- To increase the proficiency of all students within one seamless, efficient system, by providing them with the opportunity to expand their knowledge and skills through learning opportunities and research valued by students, parents, and communities
- To maintain an accountability system that measures student progress toward four stated goals

Source: SB 1162, Section 9

Senate Bill 1162 also stated clearly the required guiding principles, mission, and goals for Florida’s K-20 education system.

## Stated Goals of Florida’s K-20 Education System

### Progress Measured By:

#### Highest Student Achievement

- Student FCAT performance and annual learning gains
- Number and percentage of schools that improve at least one school performance grade designation or maintain a school performance grade designation of "A" pursuant to s. 229.57
- Graduation or completion rates at all learning levels

#### Seamless Articulation and Maximum Access

- Percentage of students who demonstrate readiness for the educational level they are entering, from kindergarten through postsecondary education and into the workforce
- Number and percentage of students needing remediation
- Percentage of Floridians who complete associate, baccalaureate, professional, and postgraduate degrees
- Number and percentage of credits that articulate
- Extent to which each set of exit-point requirements matches the next set of entrance-point requirements

#### Skilled Workforce and Economic Development

- Number and percentage of graduates employed in their areas of preparation
- Percentage of Floridians with high school diplomas and postsecondary education credentials
- Percentage of business and community members who find Florida's graduates possess the skills they need

#### Quality, Efficient Services

- Cost per completer or graduate
- Average cost per non-completer at each educational level
- Cost disparity across institutions offering the same degrees
- Percentage of education customers at each educational level who are satisfied with the education provided

Source: SB 1162, Section 9

Supplementing the specifications of Senate Bill 1162, BOE has defined eight core values it wishes to incorporate into the strategic planning process too.

## Core Values of the Florida Board of Education

### Definition

<b>Excellence</b>	Promoting the highest quality instruction, opportunity, and standards for all students
<b>Merit</b>	Rewarding high achievement
<b>Accountability</b>	Requiring responsibility for actions through measurement and outcomes
<b>Competition</b>	Providing opportunities for different entities to vie for programs offered to students
<b>Seamlessness</b>	Ensuring that all aspects of the system – including governance, standards, and accountability – are coordinated vertically and horizontally to meet the needs of students
<b>Student-Centered Service</b>	Focusing primarily on the needs of students receiving instruction and on the enhancement of learning
<b>Devolution</b>	Placing decisions as close as possible to the students
<b>Safety</b>	Ensuring that public education learning and administrative environments are secure havens for study and work

Source: Discussions with Board Chairman and Secretary

The Board’s core values clearly support and reinforce the guiding principles for Florida’s new education governance.

### Correspondence Between BOE’s Core Values and Senate Bill 1162’s Guiding Principles

CORE VALUES:	GUIDING PRINCIPLES:				
	Coordinated, Seamless System	Student-Centered System	Maximized Access and Opportunity	Equity and Academic Excellence	Flexibility and Accountability
Excellence			●	●	●
Merit				●	●
Accountability	●				●
Competition			●	●	
Seamlessness	●			●	●
Student-Centered Service	●	●	●	●	
Devolution		●			●
Safety	●	●	●		

# Agenda

- **Overview of Strategic Planning**

- General Approach

- Legislative Context

- **Recommended Framework**

- Illustrative Strategic Imperative

- **Developing BOE's Strategic Imperatives**

- Education Trends

- Getting Started

We propose an organizational scheme for BOE’s strategic plan that uses the Legislature’s specified components as the overarching framework.

**Recommended Organization and Scope of Florida BOE’s Strategic Plan**

<b>Component</b>	<b>Amount Of Detail</b>	<b>Proposed Number To Be Included In Strategic Plan</b>
<b>Guiding Principles*</b>	Minimal	5
<b>Mission*</b>	Minimal	1
<b>Goals*</b>	Minimal	4

\*Provided by the Florida State Legislature.

The Board’s own core values should be treated as an extension of the Legislature’s guiding principles.

**Recommended Organization and Scope of Florida BOE’s Strategic Plan**

<b>Component/ Sub-Component(s)</b>	<b>Amount Of Detail</b>	<b>Proposed Number To Be Included In Strategic Plan</b>
<b>Guiding Principles*</b>	Minimal	5
<b>Core Values</b>	<b>Minimal</b>	<b>8</b>
<b>Mission*</b>	Minimal	1
<b>Goals*</b>	Minimal	4

\*Provided by the Florida State Legislature.

To manage the complexity of Florida’s education system, BOE should decompose the Legislature’s stated goals into more specific sub-goals or *strategic imperatives*.

**Recommended Organization and Scope of Florida BOE’s Strategic Plan**

<b>Component/ Sub-Component(s)</b>	<b>Amount Of Detail</b>	<b>Proposed Number To Be Included In Strategic Plan</b>
<b>Guiding Principles*</b>	Minimal	5
<b>Core Values</b>	Minimal	8
<b>Mission*</b>	Minimal	1
<b>Goals*</b>	Minimal	4
<b>Strategic Imperatives</b>	Moderate to Minimal	4 to 7

\*Provided by the Florida State Legislature.

For each strategic imperative, the Secretary should define clear management objectives and propose specific supporting projects for BOE’s final approval.

**Recommended Organization and Scope of Florida BOE’s Strategic Plan**

<b>Component/ Sub-Component(s)</b>	<b>Amount Of Detail</b>	<b>Proposed Number To Be Included In Strategic Plan</b>
<b>Guiding Principles*</b>	Minimal	5
<b>Core Values</b>	Minimal	8
<b>Mission*</b>	Minimal	1
<b>Goals*</b>	Minimal	4
<b>Strategic Imperatives</b>	Moderate to Minimal	4 to 7
<b>Objectives</b>	Substantial to Moderate	16 to 30
<b>Projects</b>	Substantial	30 to 60

\*Provided by the Florida State Legislature.

# Agenda

- **Overview of Strategic Planning**

- General Approach

- Legislative Context

- Recommended Framework

- **Illustrative Strategic Imperative**



- **Developing BOE's Strategic Imperatives**

- Education Trends

- Getting Started

BOE's main challenge with regard to articulating strategic imperatives in support of each legislative goal will be finding the right degree of focus.

### Hierarchy of Selected Strategic Plan Components

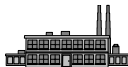
		Definition	Created And Monitored By:	
40,000 Feet		<b>Goal</b>	A measurable result that the public education system is required to achieve as part of carrying out its mission	Florida State Legislature
30,000 Feet		<b>Strategic Imperative</b>	A top-priority initiative to be completed within two to five years as a key part of achieving one of the education system's strategic goals	Florida Board of Education
10,000 Feet		<b>Objective</b>	A major milestone that the K-20 education system's management must pass on the way to implementing a strategic imperative	Secretary and Commissioner of Education (Under the Aegis of Florida Board of Education)
Ground Level		<b>Project</b>	A discrete, budgeted management effort undertaken to attain one or more defined objectives	Secretary and Commissioner of Education (Under the Aegis of Florida Board of Education)

Strictly speaking, each strategic imperative should be a major initiative (or sub-goal) supporting a legislative goal that will take two to five years to accomplish.

Established By The Legislature

Developed By Florida BOE

Defined By Secretary And Commissioner Of Education And Approved By Florida BOE

CONCEPTUAL

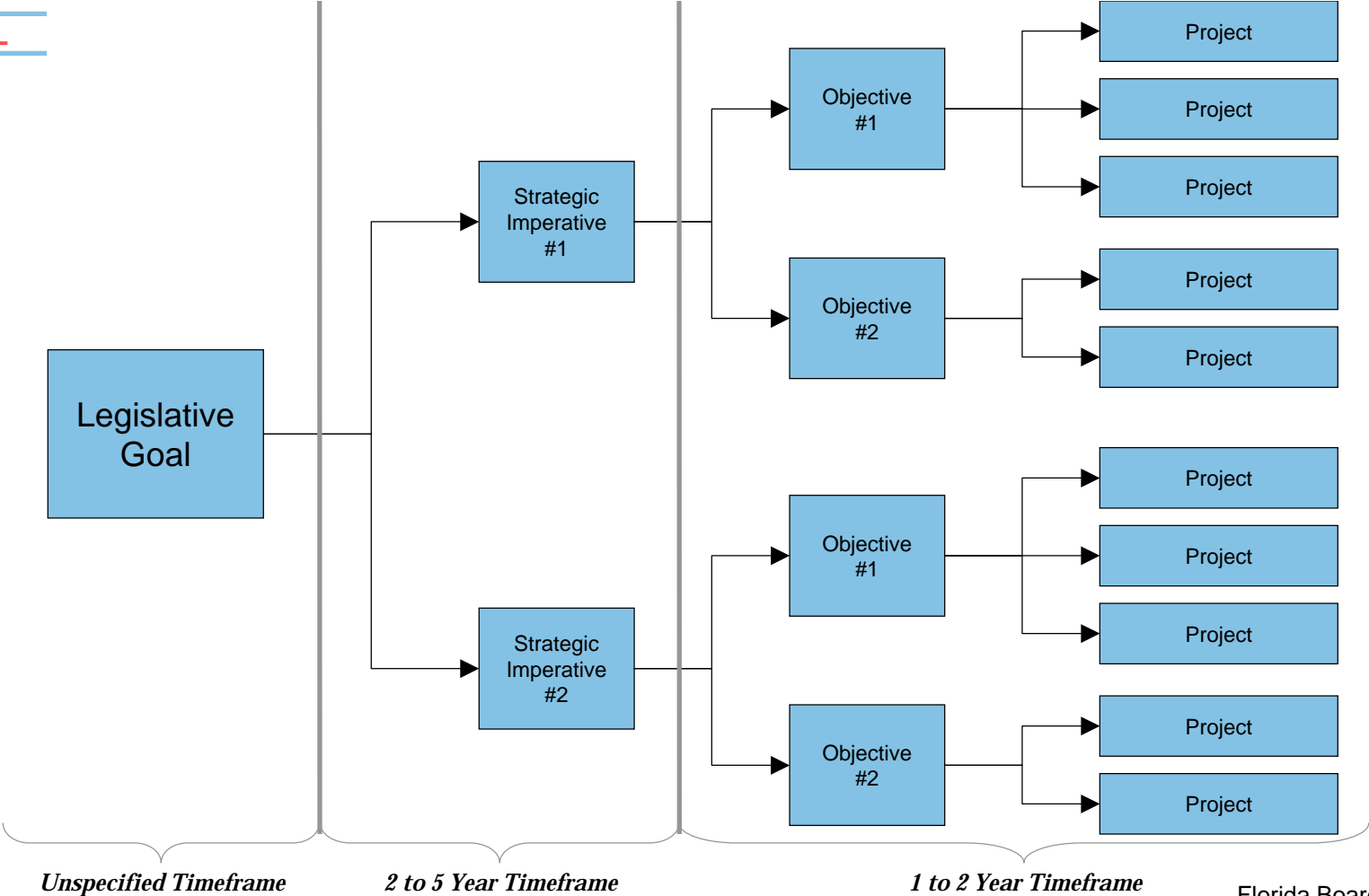

In addition, each strategic imperative should indicate a BOE priority vis-à-vis achieving the legislative goals and provide a high-level definition of success.

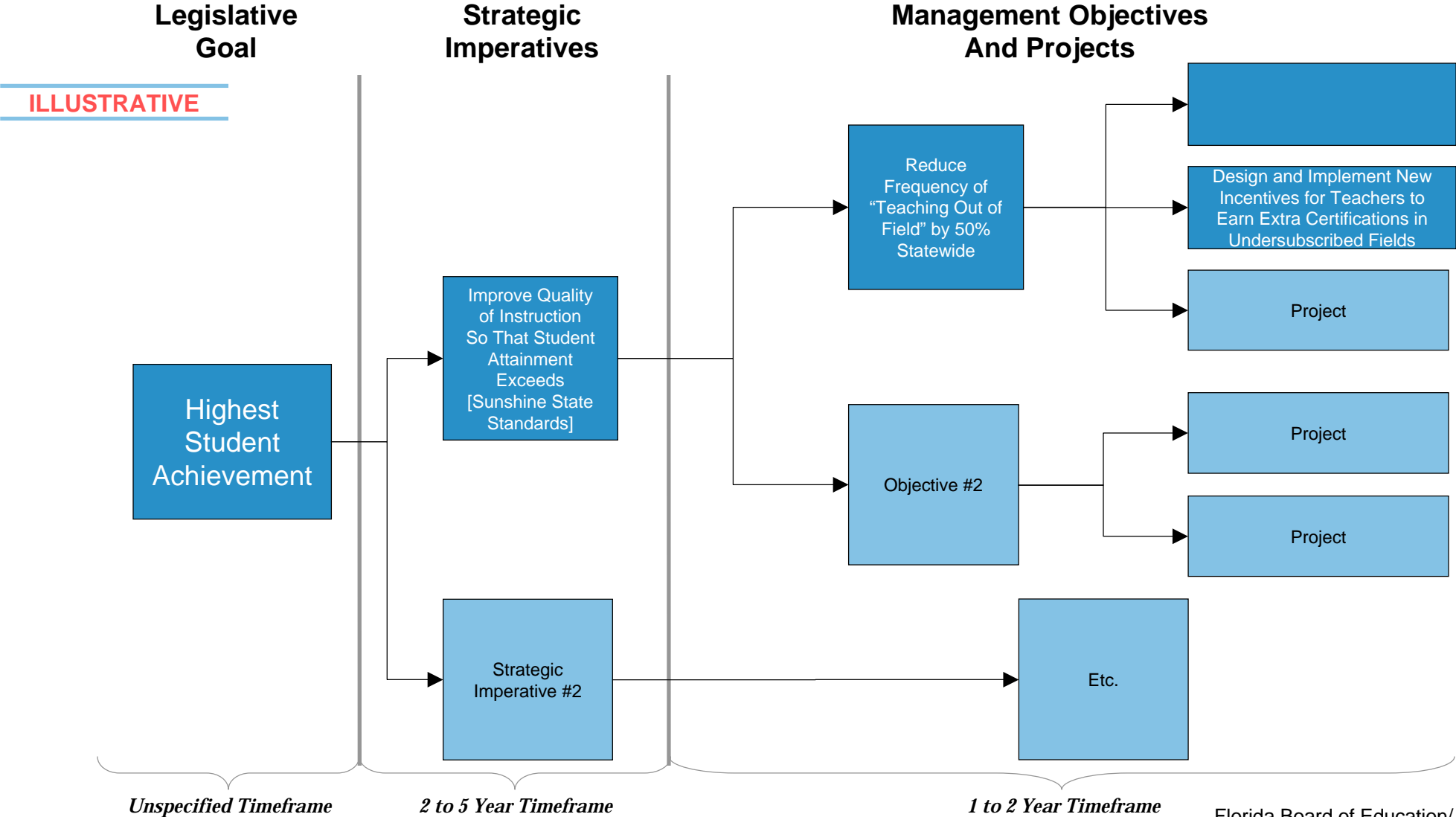

# Agenda

- Overview of Strategic Planning
  - General Approach
  - Legislative Context
  - Recommended Framework
  - Illustrative Strategic Imperative
  
- **Developing BOE's Strategic Imperatives**
  - **Education Trends**
  - Getting Started

**Trends on which the Florida Board of Education will need to focus concern both global changes in the education industry and new operating priorities.**

**Salient Trends in Education**

**Environmental and Industry Trends**

- **Education is becoming a lifelong event**
- **Education is globalizing to meet business and industry needs**
- **Education’s focus on outcomes (learning) and competencies (practical knowledge) is growing**
- **Technology is revolutionizing education**

**Operating and Service Delivery Trends**

- **Learners are increasingly being served as customers**
- **A rapidly growing number of providers offer a single point of contact – a “one-stop shopping experience” – for services**
- **In higher education, pressure is mounting to keep tuition costs down**
- **Privatization as a means of improving educational services and reducing costs is becoming more common**

Environmental and industry trends will require focus on an expanding market of learners seeking concrete results through numerous channels and providers.

### Environmental and Industry Trend Implications

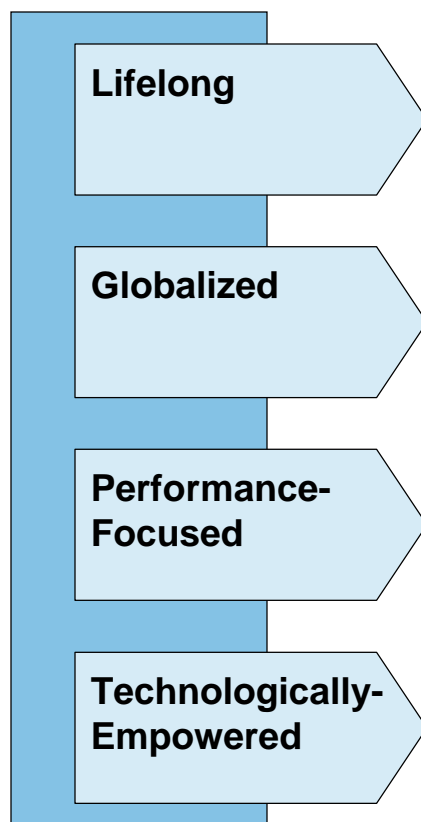

- Increased learner population size due to aging and workplace trends:
  - In 1970, 28% of students in higher education were over 24 years old
  - In 1999, the figure had risen to 43%
- New approaches and services needed to serve non-traditional students
- Growth in for-profit educational service providers with national reach
- Public school and college students targeted by virtual merchants
- Greater emphasis placed on accounting for results
- Less importance placed on traditional degrees
- Increased demand for specialized certifications
- The number of students taking distance learning courses is expected to exceed 2.2 million by 2002
- More than 80% of higher education institutions in the US will offer courses that make use of distance learning by 2004
- A small number of major online education providers eventually will dominate the distance learning market

Operating and service delivery trends will require focus on keeping current customers satisfied, enhancing revenues and controlling costs, and limiting core services.

### Operating and Service Delivery Trend Implications

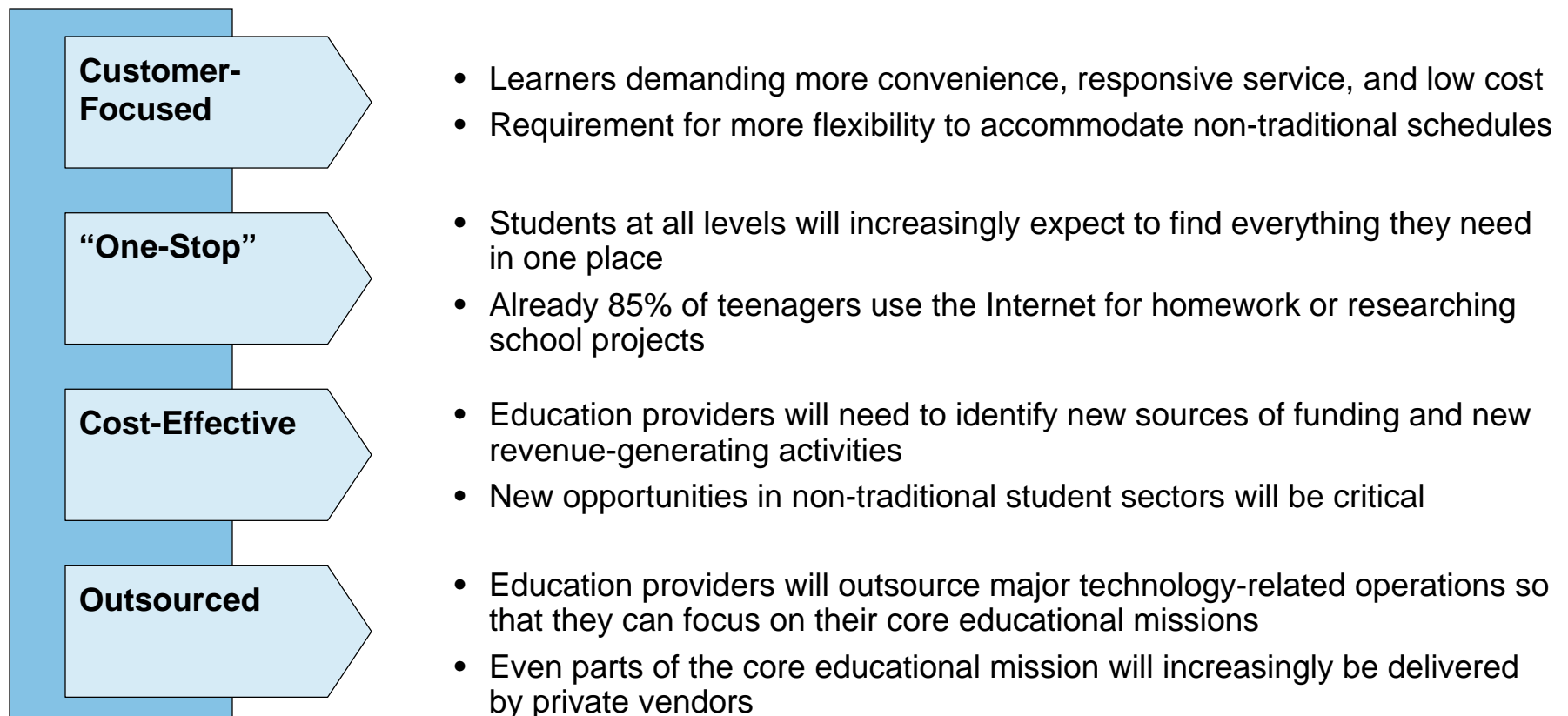

Providing quality post-secondary education will be especially important because economic growth and new jobs can be expected to go to the states best at doing this.

**US Job Growth by Education and Training Requirements, 1994 – 2005E**

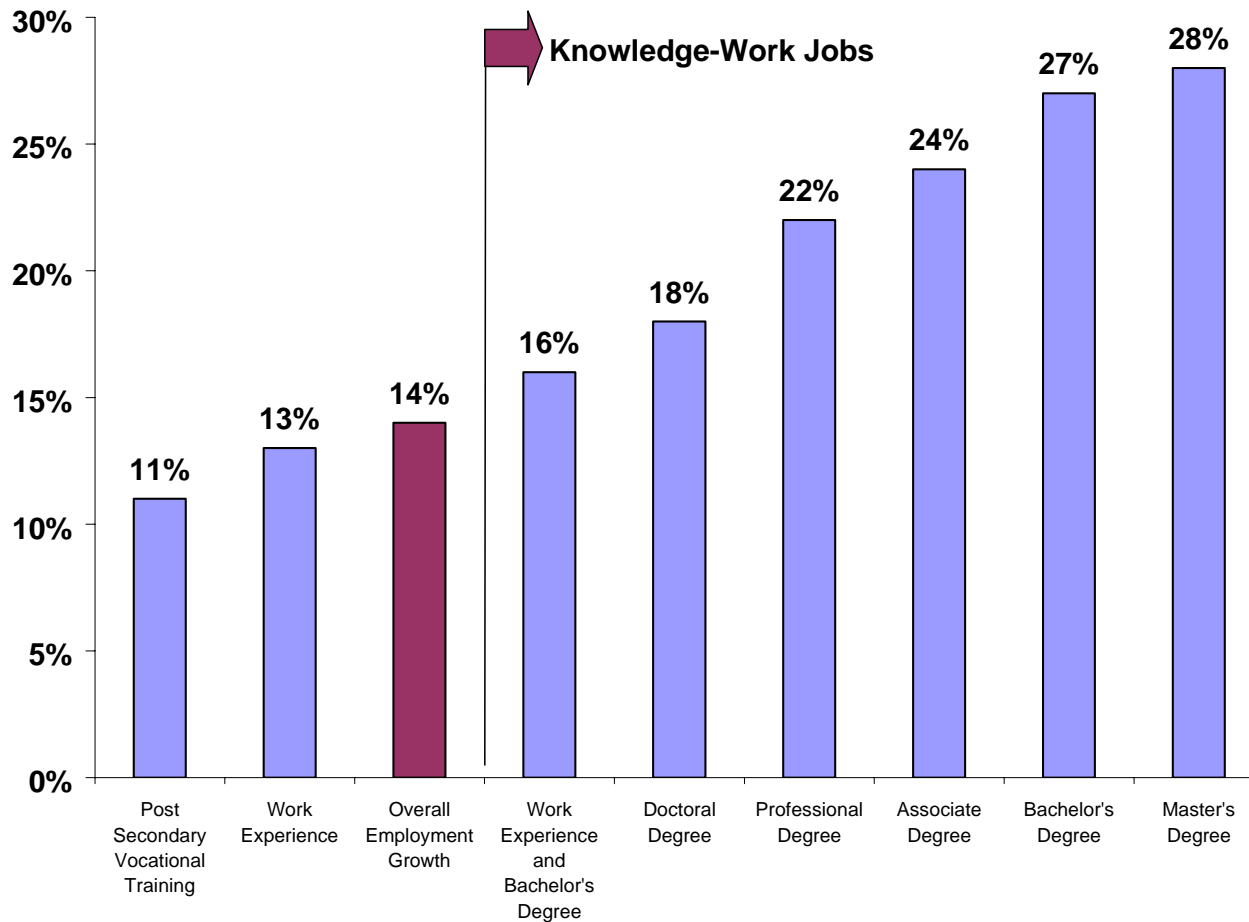

Source: Employment Outlook, 1994-2005

Moreover, providing *quality* post-secondary education now entails offering substantial technological content and support to meet new market skill demands.

US Supply of Technology Workers Compared to New Job Demand (000s), 2000

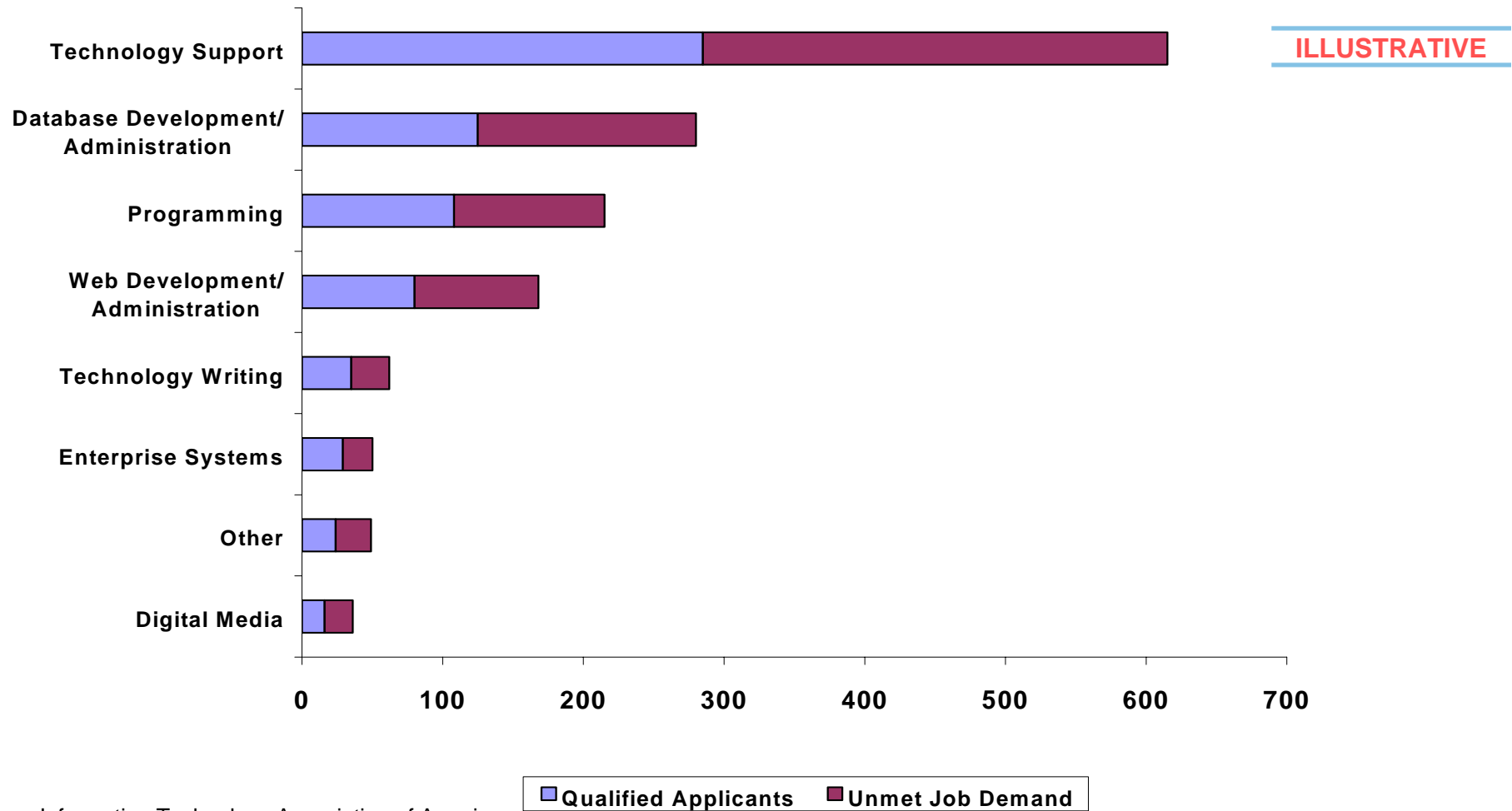

Source: Information Technology Association of America

# Agenda

- Overview of Strategic Planning
  - General Approach
  - Legislative Context
  - Recommended Framework
  - Illustrative Strategic Imperative
  
- **Developing BOE's Strategic Imperatives**
  - Education Trends
  - **Getting Started**

# Given the Legislature’s and Governor’s goals and the trends in education, what should be the strategic imperatives of the Florida Board of Education?

## Goals and Strategic Imperatives for the Florida Education System



40,000 Feet

### Goal

#### Definition

A measurable result that the public education system is required to achieve as part of carrying out its mission

#### Working List

- Highest Student Achievement
- Seamless Articulation and Maximum Access
- Skilled Workforce and Economic Development
- Quality, Efficient Services



30,000 Feet

### Strategic Imperative

A top-priority initiative to be completed within two to five years as a key part of achieving one of the education system’s strategic goals

*To Be Determined*

# Discussion

**Established By  
The Legislature**

**Developed By  
Florida BOE**

**Defined By Secretary And Commissioner Of  
Education And Approved By Florida BOE**

**CONCEPTUAL**

